

Product Information

SCA-321 Serial Communication Adapter

KAYDEN[®]
I N S T R U M E N T S

Serial Communication Adapter

The Kayden's SCA-321 is a port-powered two-channel RS-232 to RS-485 converter. It converts the TD and RD RS-232 lines to balanced half-duplex RS-485 signals. The unit is powered from the RS-232 data and handshake lines regardless of whether the lines are high or low. The Kayden SCA-321 has a DB-9 female connector on the RS-232 side, DB-9 male with a detachable 6 terminal block connector on the RS-485 side.

No handshaking is required to control the RS-485 driver. The handshake lines are required but only to provide power to the converter. The RS-485 driver is automatically enabled during each spacing state on the RS-232 side.

During the marking or idle state, the RS-485 driver is disabled and the data lines are held in the marking state by pull-up and pull-down resistors.

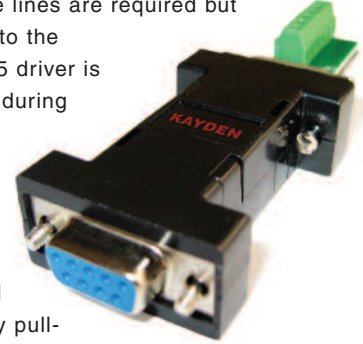

The SCA-321 has an internal connection to prevent data transmitted from the RS-232 port from being echoed back to the RS-232 port. The SCA-321 is used as a two-wire (half duplex) RS-485 converter with a third conductor to be used as signal ground. Using a common signal ground ensures that the common mode voltage between devices falls within the specifications of RS-485. This is especially important for networked devices with opto-isolated RS-485 interfaces.

Using the SCA-321 to communicate to most RS-485 devices does not usually require any termination. Termination is used to match impedance of a node to the impedance of the transmission line being used. When impedances are mismatched, the transmitted signal is not completely absorbed by the load and a portion is reflected back into the transmission line. This reflected signal could cause communication errors especially on long cable runs using a high data rate. If termination is required, the SCA-321 only supports active coupled terminators. When using terminators, one should be installed on each end of a straight cable run. A typical active termination is a 120 Ohm ¼ watt resistor and a 0.1 uF capacitor in series between 485(+) and 485(-).

Power Requirements	
	Requires at least two RS-232 output handshake lines for power.
RS-232 side	
Connector:	DB-9 Female
Signals:	Passes through pins 3 (TD) and 2 (RD). Pins 7 (RTS) and 8 (CTS) are tied together. Pins 4 (DTR), 6 (DSR), and 1 (CD) are tied together.
RS-485 side	
Connector:	6 Pin Terminal Block
Signals:	Half-duplex two-wire operation only. Automatic control circuit enables driver only when transmitting. Receiver is disabled when transmitting to prevent echo back to RS-232 device. Can transmit up to 4000 feet at 19,200 baud.

Part Number: A15-321

Dimensions: 3.8" x 1.25" x 0.7"

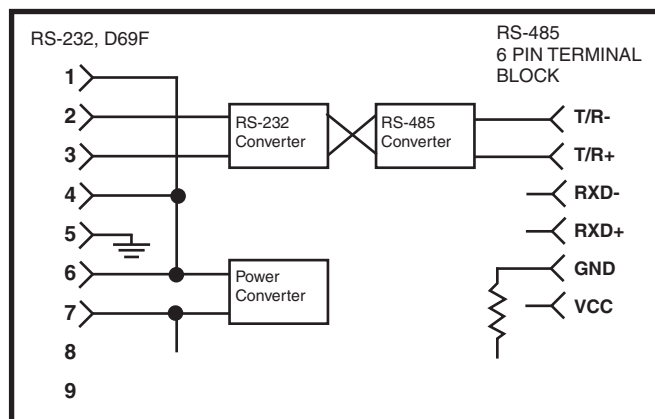

Ordering & Contact Information

Contact us with any inquiries you may have.

Telephone

1 (403) 253-1423
001 (403) 253-1423

Fax

1 (403) 253-1460
001 (403) 253-1460

North America
International

E-Mail

sales@kayden.com

Web

kayden.com

Hours Monday – Friday 8:00 a.m. – 5:00 p.m. MST

Mailing Address 3368 – 114th Avenue S.E., Calgary, Alberta, Canada T2Z 3V6

Contact a Local Distributor

Distributors

Visit kayden.com to find a local Distributor near you. Kayden Distributors provide local inventory, technical support and service.

KAYDEN®
Helping the World Switch™



For more information about the CLASSIC 800 Series or any of Kayden's other products, or to learn more about Kayden, please visit kayden.com